

W10FA3S-EHH2

10.1" NXP i.MX6 E Series HMI Panel PC



KEY FEATURES

- 10.1" 1280 x 800 PCAP touchscreen
- NXP i.MX6 Dual Core
- Fanless cooling system
- Front IP65
- 1 x USB ; 1 x RS232 /422/485; 1 x CAN BUS; 1 x Micro SD Slot ; 1 x Micro HDMI



SPECIFICATIONS

Display			
Resolution	1280x800	Size	10.1 inches
Contrast Ratio	800:1	Panel Brightness	350 nits 1000 nits(Optional)
View Angles	85,85,85,85	Active Area	216.96 x135.6 mm
Touch / Glass	Projected Capacitive Multi Touch Screen		
System Specification			
Processor	NXP i.MX6 Dual Core, 1.0GHz	Memory	1GB 2GB (Optional)
Storage	Onboard 16GB eMMC Onboard 32GB eMMC (Optional)	Operating System	Linux Ubuntu 18.04 (Optional) Android 6.0 (Optional) Debian 7.0 (Optional) Linux 4.1.15 QT 5.5 (Optional)
WLAN	Support (Optional)	BT	Support (Optional)
Mechanical			
Dimension	267 x 182 x 58 mm	Mounting	Panel mount VESA Mount (Optional)
Enclosure	Metal Housing	Cooling System	Fanless design
Cut out	244x159mm		
Environment			
Operating Humidity	10% to 90% (non-condensing)	Operating Temperature	0~50°C
Storage Temperature	-20~60°C	IP rating	Front IP65
Certification			
Certification	CE, FCC		
IO Ports			
Power Input	1 x 12V DC, 2-Pin Terminal Block	USB Port	1 x Console Port (Mini USB) 1 x USB OTG 1 x USB2.0 (Type-A)
Serial Port	1 x RS232/422/485 (Default RS232)	SD Card Slot	1 x Micro SD card slot
Video	1 x Micro HDMI (Optional)	Expansion Port	1 x mPCIe slot(for half size Wifi module)
LAN	1 x LAN RJ45 Connector with PoE(PD, 802.3 at)	CANBUS	1 x CANBUS, D-sub9

Accessory

Accessory	100~240V AC to DC Adapter Power Cord VESA screws Manual Mounting clips
-----------	--

Power

Power Rating	12V DC	Adapter	12V 50W
--------------	--------	---------	---------

DIMENSIONS UNIT:MM

Winmate W10FA3S-EHH2

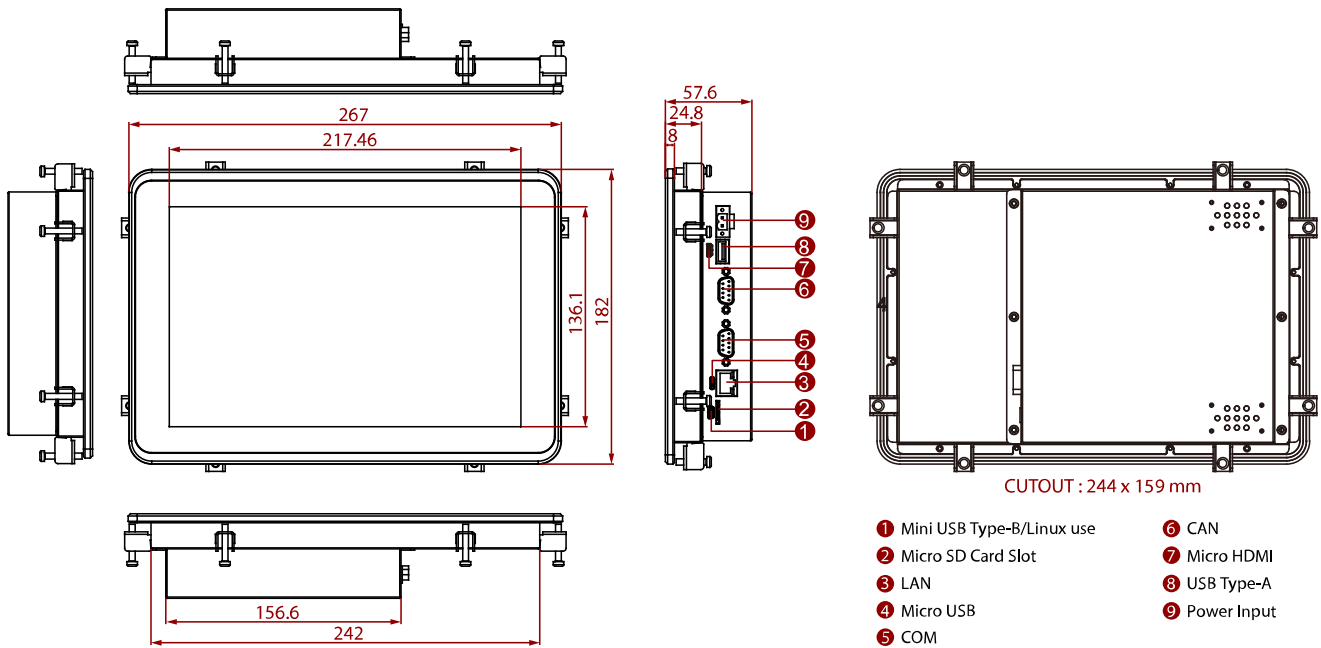

NOTE

1. This is a simplified drawing and some components are not marked in detail.
2. The product shown in this datasheet is a standard model. For diagrams that contain customized or optional I/O, please contact the Winmate Sales Team for more information.
3. All specifications are subject to change without prior notice.